

ARBO BOX INC.

**12468 PUTNAM STREET
WHITTIER, CALIFORNIA 90602
PHONE (562) 945.1687 * FAX (562) 945.0190
WWW.ARBO-BOX.COM**

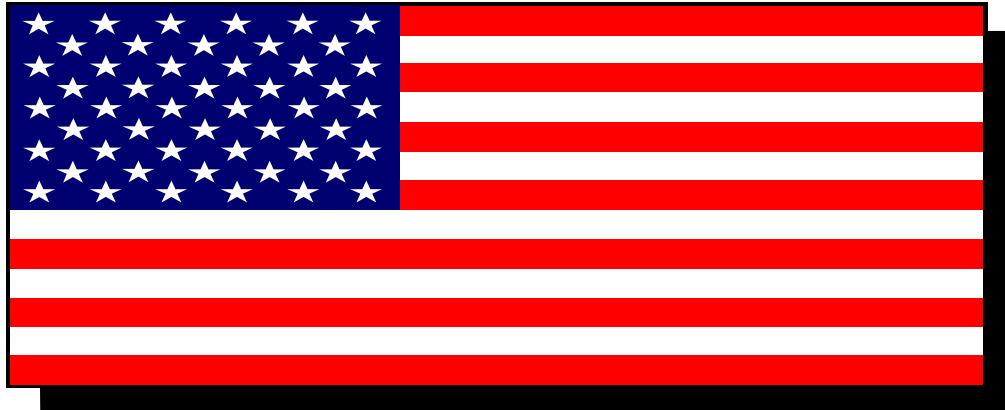

**RE-USEABLE CONTAINERS
INTERIOR PACKAGING
GOVERNMENT SPECIFICATION BOXES
EXPORT AND DOMESTIC**

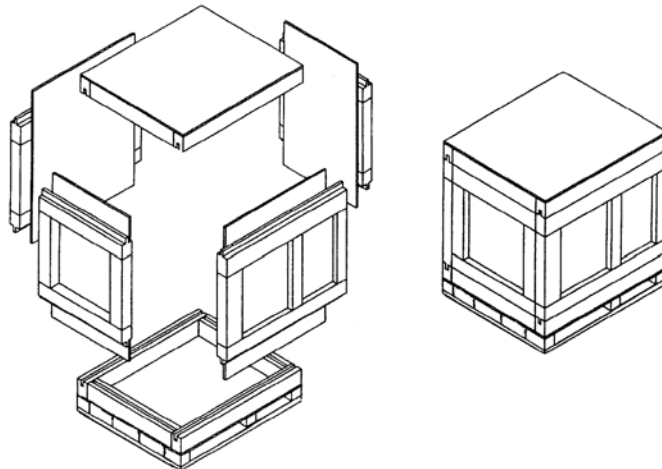

INTRODUCTION

ARBO Box Inc. has been in business for over 28 years, supporting both the military and civilian communities with embarkable transportable wooden storage containers. These containers have proven to be extremely rugged and reliable and constructed at an affordable cost.

ARBO Box Inc. designs all of their containers to support and minimize the burden of the user, thus ensuring confidence that every transported item will arrive in a safe and serviceable condition. We ensure that utility, strength, and weight are factored into each design. ARBO Inc. has received numerous awards for their unique design, which includes **two first place finishes** in the **USA's IOPP Packaging Competition**, and most recently and notably, the company won **first place for the second time** in the **Ameristar World Star Competition** held in England. The boxes are uniquely designed with our patented interlocking tongue and groove construction, eliminating the requirement for "hammer and nails," which adds years of service life to each box, resulting in a substantial savings to the customer. This design also helps to protect the contents from water damage during inclement weather. Another outstanding feature of our box design is its knock down capability that decreases the storage space requirements by up to two thirds while the box is not being used. This design not only increases the box's value but also allows for quick reassembly in less than two minutes by one person. All of our containers are built with the best A - C grade shop plywood available and reinforced with 2" x 3" cleats. All of our "knock down" containers are built on a rigid skid base with forklift access to all four sides. This reduces the amount of time required during handling without decreasing the strength of the box itself.



HOW IT WORKS.....

Designed with a patented, interlocking tongue and groove system our containers provide a rigid, simple to assemble and disassemble, and transportable container. This feature also helps keep the contents dry during inclement weather. Each knock down container is built on a rigid skid base with access to all four sides for rapid forklift use without decreasing the strength of the box itself. As shown in the diagram below, our patented design gives a secure, self-supporting, mobile container that allows for immediate deployment to or from any point of origin within a moment's notice. This design proved to be invaluable during the rapid deployment of military forces to Desert Storm.

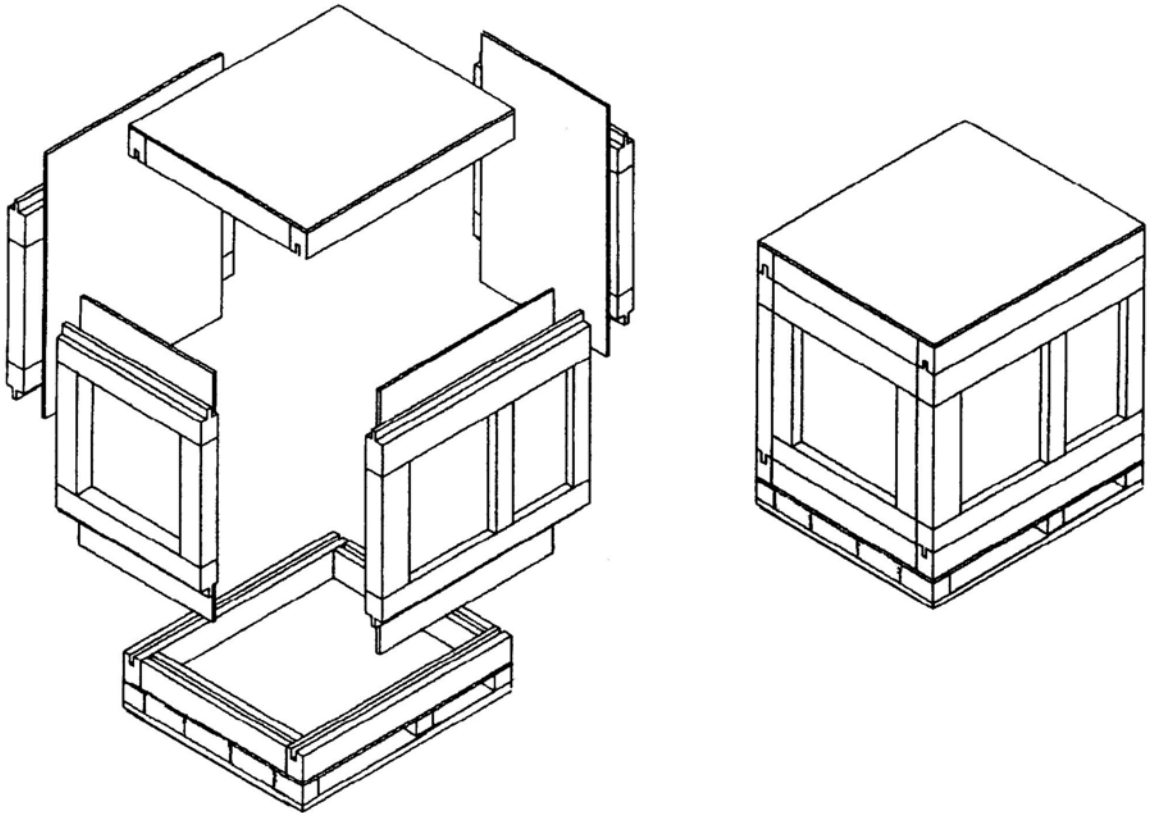

PUBLICATIONS BOX.....

Built as a set, the publications box up container and unlike the other ARBO containers does not “knock down.” The lid is attached with the same tongue and groove concept, protecting the contents from inclement weather. One of the greatest design features of this box is that once you arrive at your destination, you merely have to remove the lid and you can stack the boxes having complete and immediate access to all your publications and files. The “pubs box” is constructed with 1/2-inch plywood and 2” x 3” cleats and is extremely durable. The pubs box also comes with metal link locks attached to the lid, allowing the contents to be secured.

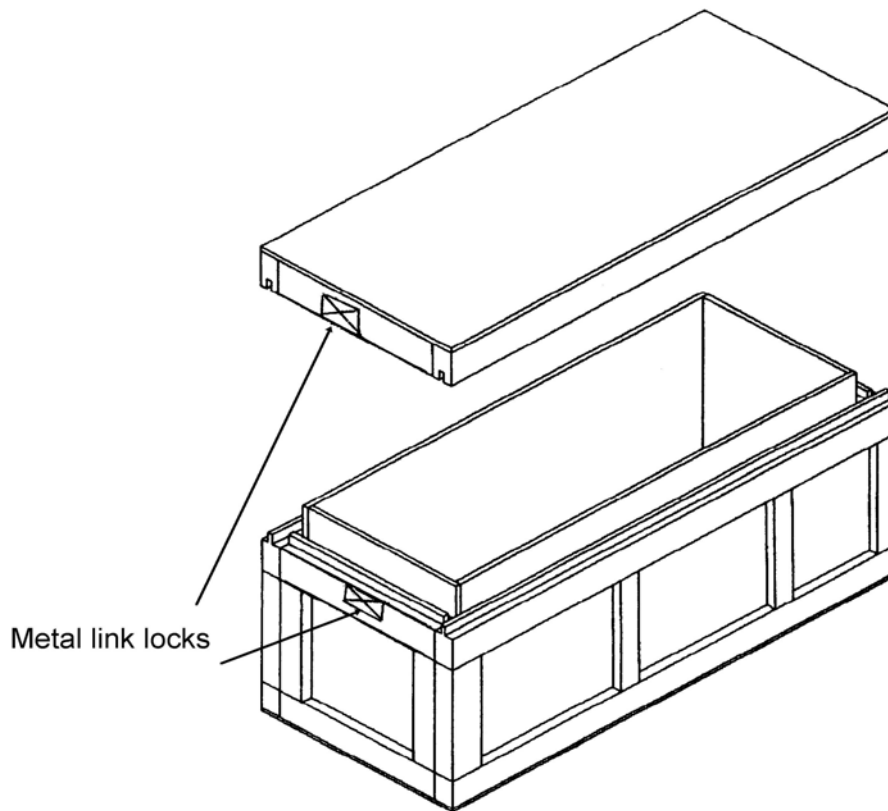

WAREHOUSING WITH ARBO BOXES.....

Another added characteristic of the ARBO box is its ideal use for warehousing. Warehousing allows the user to organize and stock all equipment and supplies in an exact location. This can also be extremely beneficial for inventory requirements. Not only can the boxes be stacked on top of each other saving valuable space, but the front panel of each box can also be removed allowing continual 24-hour access to its contents. If it is necessary to move the boxes to a different location, you only have to place the front panel back on the box and it is ready to transport in a moment's notice. The following pictures show some examples of the valuable space saving benefit of the ARBO box when used for warehousing.



ARBO Box Inc 12468 Putnam St.
Whittier, Ca 90602
Tele (562) 945-1687 Fax (562) 945-0190
www.arbo-box.com

STORAGE SPACE SAVINGS DESIGN.....

Another design feature that makes the ARBO box superior to all other competitors is its capability to be knocked down saving up to 66 percent of the space required when the box is not in use. This design helped one of our major customers save over \$1 Million dollars in warehousing costs, which not only benefited this customer but also won us an award. The following pictures help demonstrate this important feature and will give you some ideas on how this characteristic can benefit your requirements.



FEATURES.....

Proven dependable containers with long service life

Patented design eliminates requirement for nailing boxes, increasing longevity and at a considerable cost savings over time

Patented interlocking structure design protects from inclement weather

Knock down construction saves money on replacing damaged sections instead of entire box

Four-way forklift access reduces handling time

Standard size design uses maximum Sq/Cu feet on 463L pallets and ISO containers

Standard size eliminates blocking and bracing requirement when used inside the ISO container, saving a substantial amount of money, time & labor

Front panel design allows access to contents without un-stacking boxes

Knock down design reduces storage space requirement by up to two thirds for each box

Meets or exceed all of the government specifications for shipping under Spec. PPP-B-601

Outstanding company reputation throughout both the military and civilian communities

Boxes constructed with best C grade shop plywood available, increasing the life of containers

Exceptional support record of meeting or exceeding all required delivery schedules

ARBO Box Inc 12468 Putnam St.
Whittier, Ca 90602
Tele (562) 945-1687 Fax (562) 945-0190
www.arbo-box.com

HOW TO PURCHASE.....

The ARBO Box Inc. is located at 12468 Putnam Street, Whittier, California 90602. You may purchase boxes by calling the ARBO Company at (562) 945-1687 and requesting a quote, online at www.arbo-box.com or fax for quote to (562) 945-0190. We remain available to meet and discuss all requirements you may have and how to best support each request. Though we have only shown certain standard size boxes, we can readily construct any size box with the same ARBO commitment to fit your requirements. On our website, we have numerous photos of military and civilian crates to show the vastness of our product. ARBO has an established record of meeting or exceeding all delivery schedules, even when minimal time is required to build and ship our product. We highly value our customers and look forward to supporting all your needs in the future.



FRONT PANEL CONTAINERS.....

The diagram below exemplifies the technique used to employ this container. Notice that on the top section of the removed panel, there is no extension of plywood, or tongue and groove, permitting quick and easy loading and unloading of the container. Further, notice the open and removed front panel is constructed to allow the containers to remain stacked, with their contents always accessible, as when used for warehousing. The diagram also shows 4-way access for rapid forklift use. These containers come in standard sizes of 42, 63 and 84 Cubic Feet.

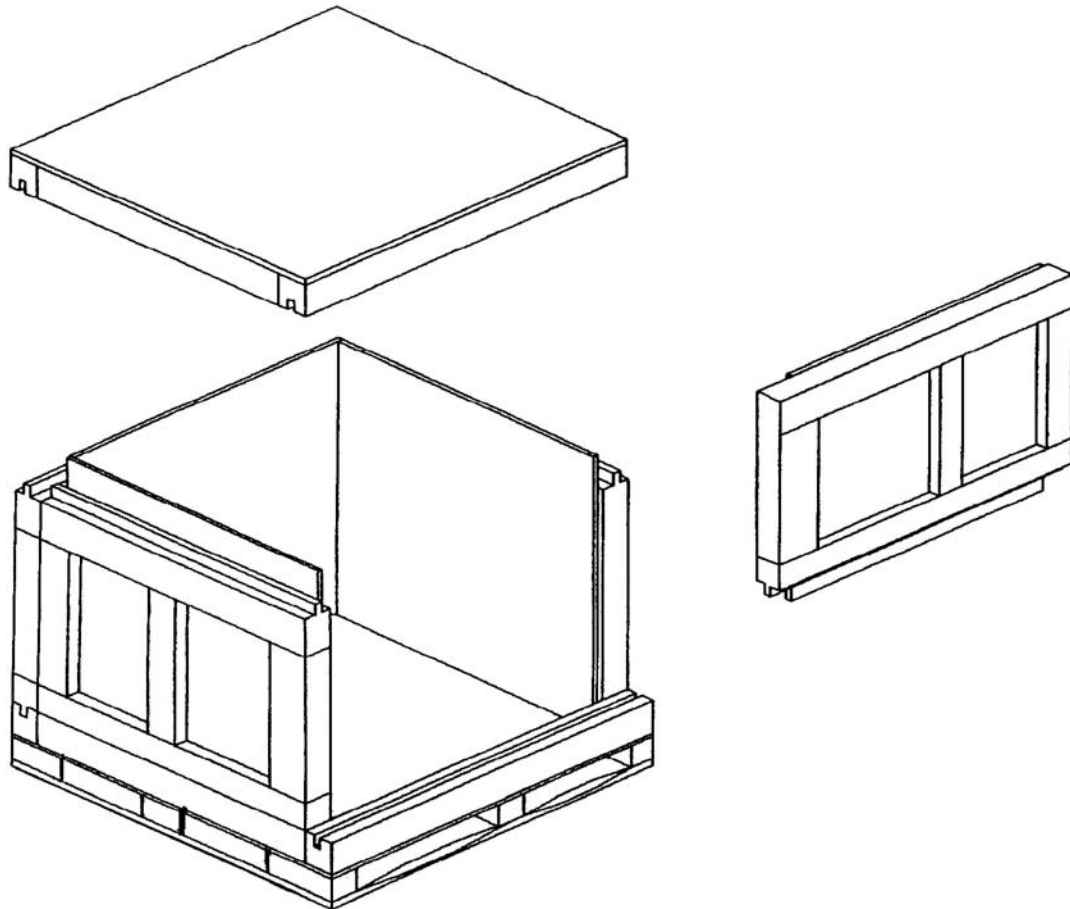

ARBO Box Inc 12468 Putnam St.
Whittier, Ca 90602
Tele (562) 945-1687 Fax (562) 945-0190
www.arbo-box.com

INTERMODEL CONTAINERIZATION PROGRAM.....

Desert Storm revealed a substantial amount of money was used for the enormous amount of lumber required for blocking and bracing for the thousands of ISO containers used by the services to deploy. This problem was resolved by the ARBO Company slightly modifying the sizes of its standard containers. The new design continues its easy loading feature, but used in conjunction with the ISO container, the requirement for blocking and bracing is eliminated, saving a substantial amount of money for both materials and labor to deploying forces. The new design also allows for maximum use of square and cubic feet when used with the 463L Air Force pallet. Another key feature when using the ARBO boxes in conjunction with the ISO containers is that it allows for the simultaneous, rapid and orderly forward movement of the contents within the ISO containers to multiple sites within the theater of operation. These features are demonstrated in the following photographs.





ARBO Box Inc 12468 Putnam St.
Whittier, Ca 90602
Tele (562) 945-1687 Fax (562) 945-0190
www.arbo-box.com

M-16 RIFLE BOX.....

The M-16 rifle box is made of the same tongue and groove construction that helps eliminate moisture from inclement weather. It also comes with metal link locks on each end for additional security. Each box is inlaid with a slotted foam material that not only holds the weapons in place but also protects them from damage during shipping. Each rifle box can support 5 M-16 rifles.



COMPUTER WORK STATION

The computer workstation container is one of the newest designs in the ARBO inventory. It is a self-contained workstation able to store and transport an entire standard size computer suite, including the main frame, up to a 19-inch monitor, printer, keyboard and all required cables, as well as a storage section for extra computer software. The unique feature of this box is that once you take off the front and back sections of the container, you merely have to hook up the cables and you are ready to operate your computer. The front and back sections of the container with their built in metal legs, attach to the base, giving you two 5 feet long by 3 feet deep tables. It also has a tray that slides out to place your keyboard on. The container is completely insulated to protect the contents from damage under the most abnormal shipping conditions. Because the computer workstation is self-contained, it takes the place of other additional equipment that would have to be deployed to support even the smallest units, saving both time and money. You can see in the following pictures how securely and easily the computer with all of its components fits into the computer container.



ARBO Box Inc 12468 Putnam St.
Whittier, Ca 90602
Tele (562) 945-1687 Fax (562) 945-0190
www.arbo-box.com

COMPUTER WORK STATION CON'T.....

The ARBO computer container is easy to assemble and can be completely ready for us in a few minutes.



This picture shows how easy and secure it is to deploy an entire computer station within the ARBO computer container.



This picture shows a computer workstation fully operational. Each computer workstation is completely ready for use in just a few minutes by removing the front and back panels, locking them onto the base and attaching the computer cables.



ARBO Box Inc 12468 Putnam St.
Whittier, Ca 90602
Tele (562) 945-1687 Fax (562) 945-0190
www.arbo-box.com

FLEXIBILITY AND EASE.....

This container shows the flexibility to adapt to all design requirements, such as adding special shelves to store sensitive items.



This photograph shows the ease of front panel removal allowing easy access contents even when stacked and used for warehousing.



ADDITIONAL MILITARY CRATES

Case for TV and Dish



Beverage Container



Boat Motor (2 Motors)



ARBO Box Inc 12468 Putnam St.
Whittier, Ca 90602
Tele (562) 945-1687 Fax (562) 945-0190
www.arbo-box.com

ADDITIONAL MILITARY CRATES

Tow Site Assembly



M3 Tripod, Barrel, Spare Set



Pistol Box with Magazine tray

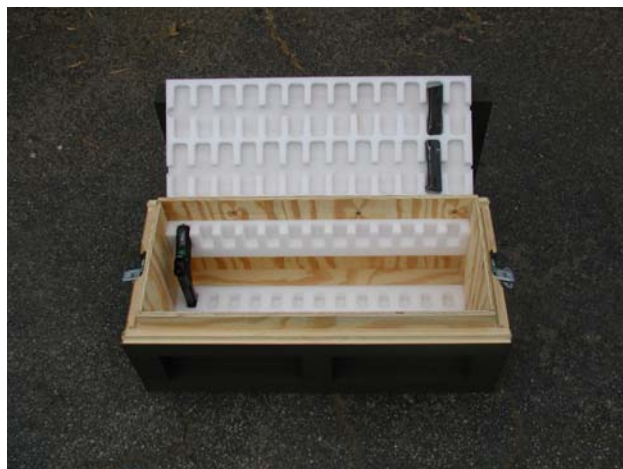

ARBO Box Inc 12468 Putnam St.
Whittier, Ca 90602
Tele (562) 945-1687 Fax (562) 945-0190
www.arbo-box.com

SPECIAL EQUIPMENT BOXES.....

The ARBO Company prides itself on combining its unique design structure with the most up-to-date engineering and safety standards. This combination provides maximum flexibility, ensuring that all requirements for a secure shipping container can be easily met. The box constructed below reveals a specially designed ramp that also doubles as the front panel of the box. This design allows for the easy loading of equipment that is capable of being rolled. Another valuable feature of this container is its padded design, which eliminates the requirement to bolt down the equipment inside the box. This container is also constructed with a spring cushioning system imbedded in the false bottom panel, which provides required shock and vibration performance based on equipment configuration and weight. These features not only save time and money, but also ensure the least possible damage to the equipment. Of course, as with all the ARBO designed boxes, this container can be used continuously, not only helping ensure your equipment arrives safely, but also reducing future shipping costs.



ARBO Box Inc 12468 Putnam St.
Whittier, Ca 90602
Tele (562) 945-1687 Fax (562) 945-0190
www.arbo-box.com

ARBO Box Inc. prides itself on its years of service to the military and civilian communities. It is proud of the reputation it has built maintaining an outstanding working relationship with its valued customers, while also providing a more superior product than its competitors have. ARBO Inc. is dedicated to maintaining this working relationship along with its reputation of always being on or ahead of schedule and will continue to seek new and inventive ways to improve on this support. We look forward to working with all facets of both the military and civilian communities in the future and would be happy to discuss with you how we may help resolve any packaging and/or storage problems you might have.

